

Puris[®]



Puris, Evo-CB Water System

Model : Evo-CB Series

User Manual

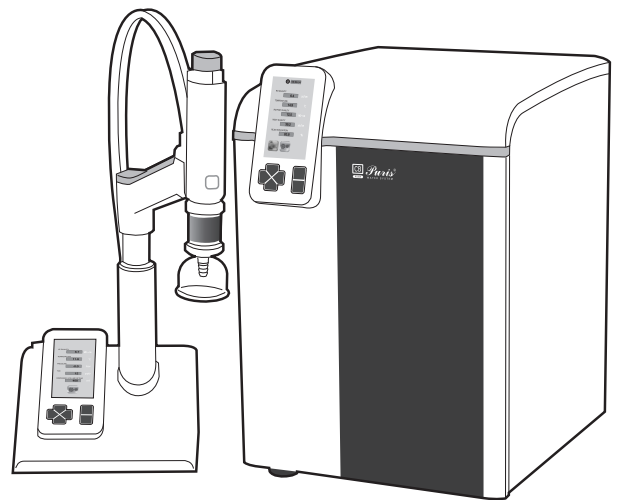

Foreword

This manual is provided to serve as the installation, operation and maintenance guide for the Evo-Series

LAB Water system models.

The manual should be read before attempting any cycle of installation, operation and maintenance. If the instructions in this manual are not followed, the performance of this product or the safety of the user may be compromised.

If the problem cannot be solved with using this manual, please call your distributor or the manufacture.

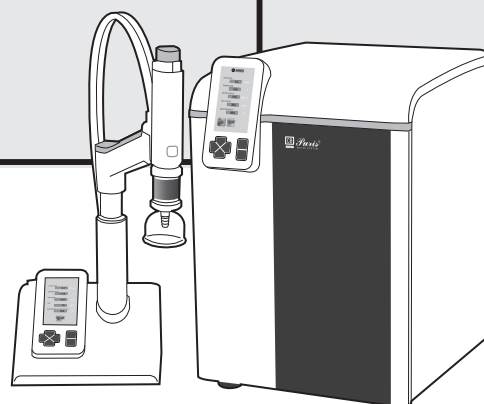





Safety Operation

Evo-CB Water System functions as described in this manual.

Follow the instructions in this manual for correct usage and filter replacement. Failure to do so may result to the malfunction and breakdown of Evo-CB Water System. If any encountered problem persists, contact the Mirae ST customer center for professional assistance.

Safety Symbols

The following symbols are designed to guide you through Evo-CB Water System operation.

	AC(Analternating Current)
	An Earth
	On
	Off
	FUSE

Contents

Section 1. User Manual Outline

- 1-1. General outline
- 1-2. Customer Center

Section 2. Product Details

- 2-1. Merits of Evo-CB System
- 2-2. Water Quality
- 2-3. Dimensions and Weight
- 2-4. Installation Environment

Section 3. System Installation

- 3-1. Before Installation
- 3-2. Unpacking
- 3-3. Main Unit Installation
- 3-4. S-Dispenser Connection
- 3-5. Pure water storage tank
- 3-6. Printer Connection

Section 4. System Operation

- 4-1. Keypad
- 4-2. Date and Time
- 4-3. Initial Screen
- 4-4. Menu Setting
- 4-5. Pure and Ultra pure water production window
- 4-6. Quantity Control
- 4-7. Water Quality Printout
- 4-8. Filter Replace Alarm
- 4-9. USB Auto Save

Section 5. System Maintenance

- 5-1. Replacing of the Dico-PC Pack, Dio Pack III
- 5-2. Replacing of the Dico-RO Membrane
- 5-3. Replacing of the UV Lamp
- 5-4. Replacing of the UF Filter, Final Filter
- 5-5. System Resetting after filter replacing
- 5-6. Component Replacement Cycle
- 5-7. Maintenance

Section 6. System Alerts

Section 1. User Manual Outline

1-1. General Outline

This manual guides you through the installation, operation, and maintenance of Mirae ST Evo-CB System. You will find that using Evo-CB system is very simple, if you take the time to read this manual beforehand. Contact the Mirae ST customer center if you have any inquiries.

1-2. Customer Center

Mirae ST Head Office

- Phone : 031-420-5753
- Fax : 031-420-5978
- Web site : www.miraest.co.kr
- E-mail : mrst@mrst.kr

Section 2. Product Details

2-1. Merits of Evo-CB System

- One-touch tubing lets even the first-time users of the Evo-CB Series to install Evo-CB System easily.
- Installation space is minimized by the S-Dispenser, the first one of its kind in Korea. Evo-CB System can be used safely in laboratories.
- Evo-CB System's quiet pump is perfect for all environments.
- Water quality, water level, and system status are all displayed on a 4.3"-wide graphic display. Settings can be made on both the main unit and the S-Dispenser.

2-2. Water Quality

	Evo-CB Dio 10	Evo-CB Dio 20	Evo-CB Dio UV	Evo-CB Dio VF	Evo-CB Dio VFT
Flow Rate (Up to) RO(L/hr)/UP(L/min)	10/2.0	20/2.0	10/2.0	10/2.0	10/2.0
Product Quality - Conductivity (RO), μs/cm - Resistivity (UP), MΩ-cm - TOC (ppb)μg/L	1-25 18.2 <10	1-25 18.2 <10	1-25 18.2 <5	1-25 18.2 <5	1-25 18.2 <5
Particles (0.2 μm)	<1	<1	<1	<1	<1
Bacteria, cfu/ml	<1	<1	<1	<1	<1
Endotoxin, EU/ml	-	-	-	<0.001(*)	<0.001(*)
Rnase, ng/ml	-	-	-	<0.01(*)	<0.01(*)
Dnase, pg/μl	-	-	-	<4(*)	<4(*)

(*) with UF Filter

2-3. Dimensions and Weight

- Dimensions
 - Main System : W350 × D430 × H520(mm)
 - S Dispenser : W235 × D180 × H635(mm)
- Weight
 - Main System : 20~22.5kg
 - S Dispenser : 5.0kg

2-4. Installation Environment

2-4.1 Water Supply

- Condition for water input

	RO	UP
Reverse osmosis water	<250 μ s/cm	Reverse Osmosis Water, DI(Deionization) Water, Distilled Water
Temperature	5-40°C	5-40°C
Pressure	0.07-6bar	0.9Bar
Chlorine	\leq 3ppm	\leq 0.07ppm
Fouling Index (SDI)	\leq 12	
TOC		\leq 50ppb
Silica		\leq 3ppm
Influx	20L/hr or 40L/hr	100L/hr

2-4.2 Power Supply

- 220-240v, 50-60Hz or 110-120v, 50-60Hz

2-4.3 Installation Environment

- Installation temperature : 4 ~ 40°C
- Environment type : Indoors
- Altitude : 2,000 m or less
- Pollution Degree : 2

Section 3. System Installation

3-1. Before Installation

3-1.1 Power Supply

- Plug in the power cord correctly.
- Make sure that the correct level of power is supplied.
- Do not open or disassemble the main PCB (Printed Circuit Board).
- Never tamper with the lines in the main PCB and sensor.
Program or sensor malfunction may result.

3-1.2 Location

- Install Evo-CB System on a laboratory table or a flat horizontal surface.
- Install Evo-CB System on a table - not floors or surfaces on which Evo-CB System might become contaminated.

3-1.3 Relocation

- Before relocating Evo-CB System, turn off the tap and remove all tubing from the tap and the back of Evo-CB System.
- Remove all packs from the inside of Evo-CB System before relocation.
Failure to do so can result for the Quick Connector to become damaged.

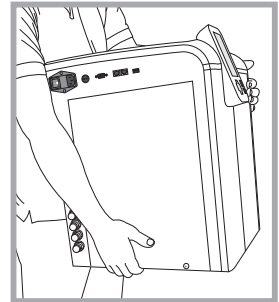

3-1.4 General Safety Precautions

- Keep Evo-CB System away from alcohol and inflammables.
Electric shock or fire can be created if an inflammable material comes in contact with the electrical components inside Evo-CB System.
- Keep the top of Evo-CB System free from any objects because it negatively affects the function of electrical components.
- Keep Evo-CB System and the pure water tank out of direct sunlight.
Direct sunlight can spread microbes.
- Keep Evo-CB System at room temperature.
Excessively high or low temperatures can deteriorate the filter and PCB.

3-2. Unpacking

- Remove Evo-CB System from its packing and check if all components are there.
- Place Evo-CB System on a flat horizontal surface in a safe environment.

3-2.1 Components

Puris, Evo-CB Water System Unit : 1SET

- Built-in filter
 - RO Membrane : 1EA (For Dio10, UV, VF, VFT)
: 2EA (For Dio 20)
 - UV Lamp : 1EA (For Dio UV, VF, VFT)
- Removable filter
 - Dico-PC Pack : 1PK
 - Dio-Pack III : 1PK
 - Dio-UF Filter : 1EA (For Dio VF, VFT)
 - Final Filter : 1EA (For Dio 10, 20, UV)
- Power cord : 1EA
- Tubing kit
 - 5/16" tubing : 4EA (For Feed, Drain, Product, UP Inlet)
 - 3/8" tubing : 1EA (Tank overflow)
 - Cable Tie : 1SET
- User manual : 1EA

3-3. Main Unit Installation

- Place the main unit in the location where it is to be installed and install as follows.
- Influx and drainage must be possible in the installation location.
- Locate the main unit beside or under the pure water tank for optimum influx.
 - Remove the plug-in place to prevent leakage before connecting the tubing to the side of the main unit.
 - Press down on the area marked "Collect" and pull to remove the plug.

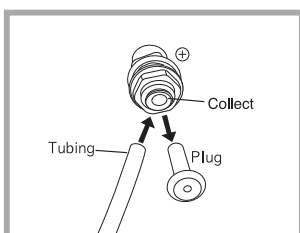



- Connect the 5/16" and 4/1" tubing to the area from which the plug was removed.

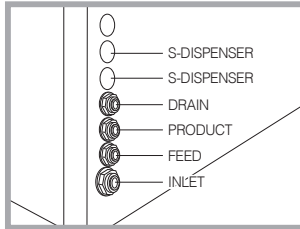

- Inlet (UP) - Connect the 5/16" tube to the Pure water tank
- Feed - Connect the 1/4" tube to the influx.
- Product - Connect the 1/4" tube to the Pure water tank.
- Drain - Locate the 1/4" tube to the drainage.
- S-Dispenser - Connect to Dispenser.



Caution : If the Inlet(UP) and Product line are not connected to the Pure water tank directly, the pump may become damaged. Your product warranty does not cover this damage.

- Open the front door of Dico-PC Pack, Dio Pack III and connect to the Quick Connector.
Press down on the top part of the Quick Connector before installing the packs on the main unit.

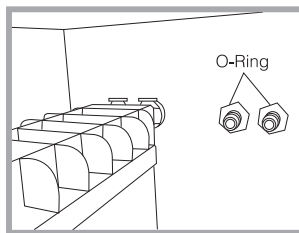
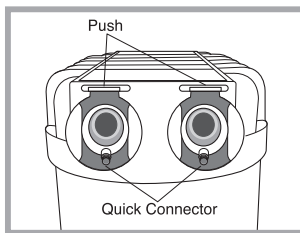

Caution : If left protruding, the top part of the Quick Connector can damage the O-ring in the main unit. Press down on the top part of the Quick Connector before installing the packs on the main unit.

- Install the UF Filter, Final Filter on the cork where ultrapure water is produced.

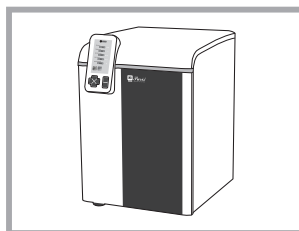
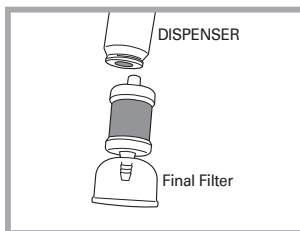

B-Dispenser

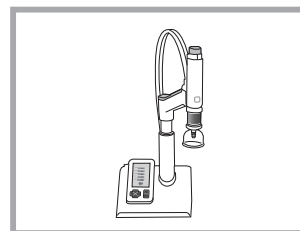

S-Dispenser

- Connect the power cord at the left side.

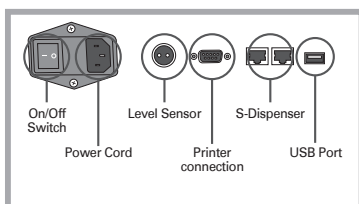

3-4. S-Dispenser Connection

Take the S-Dispenser out of its box and connect it to the main unit.
System settings made on the main unit or S-Dispenser are applied to both units.

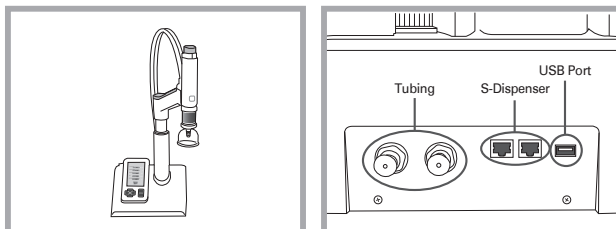

S-Dispenser

3-5. Pure Water Storage Tank

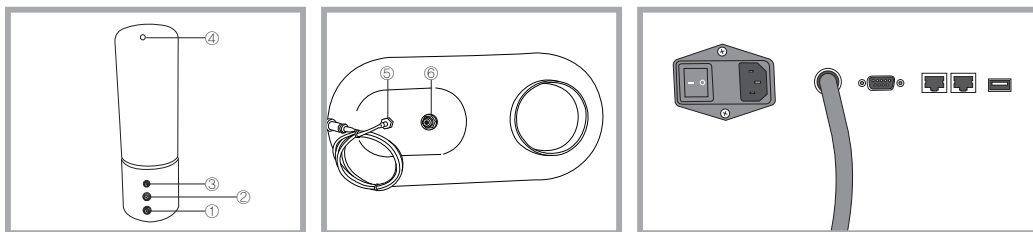

Level sensor connection of the system

- ① Drain – Locate the 3/8" tube to the drainage.
- ② UP Inlet – Connect the 5/16" tube to the main unit (when UP System or CB System is in use).
- ③ Product – Connect the 1/4" tube to the main unit in order to store produced water. (when RO System is in use).
- ④ Overflow – It is placed at the drain hole as linked with the 3/8" line.
- ⑤ Level Sensor – It adjusts the water level of the tank as linked with the system.
- ⑥ Vent filter – It is installed in 35-L or 100-L tank

3-6. Connecting the System with the Printer

- Connect the power cord to the printer and connect the printer to the main unit.

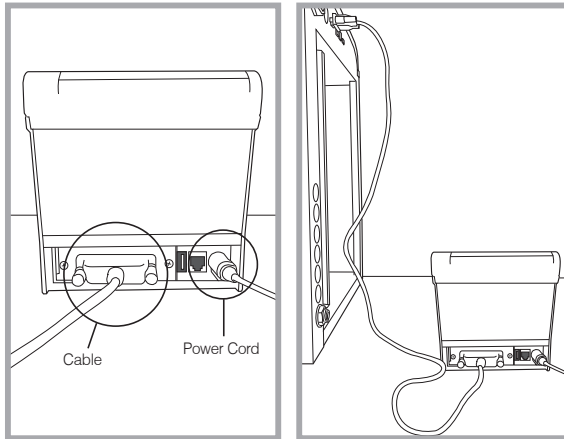

Section 4. System Operation

4-1. Keypad

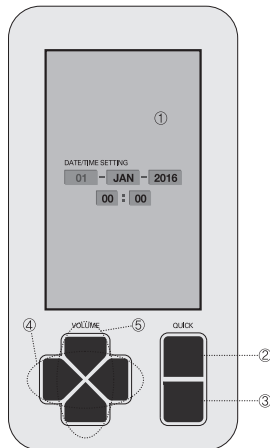

- ① LCD monitor
- ② Quick - Use this button to check the remaining pack level when the filter icon is displayed on the screen.
- ③ Menu - Use this button to automatically save changes and return to Menu.
- ④ ◀ ▶ - Use to navigate items.
- ⑤ △ ▽ - Use to make changes.

4-1.1 Icons



- Evo-CB System is in operation.



- Pure water is produced. The quantity stored in the tank is displayed.



- Ultrapure water is being collected.

4-2. Date and Time

- The time setting screen is displayed when Evo-CB System is first started. Press Δ , ∇ to set the time.
- Press Menu to save the changes made and move to Menu.

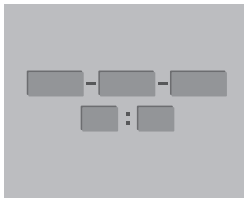

(Before Setting)

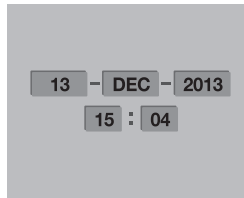

(After Setting)

4-3. Initial Screen

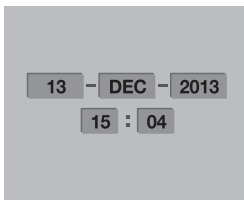

- Saved date and time are displayed.

4-4. Menu Setting

- ※ This item is the factory default setting, so you do not need to reset.

4-4.1 Quality

- The unit of pure, ultrapure water can be set in quality.



Ultrapure water can be set in units of $M\Omega\text{-cm}$, Pure water can be set in units of $\mu\text{s/cm}$.

Set Point automatically stops ultrapure water production if a set water quality is not achieved within a set time.

(Default - Ultrapure water : 15.0MΩ-cm Pure water : 25μs/cm)

Press Menu to save and return to the Menu.

4-4.2 Setting

- In Settings, UP Auto Standby, UP Circulation, UF Cleaning, Pressure, Temperature, Key Tone, and Password can be set.

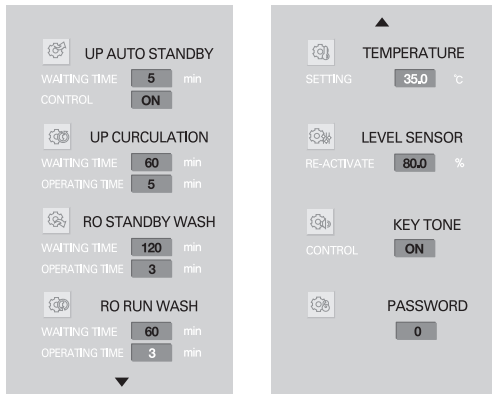

- UP Auto Standby

Evo-UP System is put on standby from circulation mode if not used for longer than a set time (default: 5 min) to prevent idle pump rotation.

- UP Circulation

Automatically circulates ultrapure water (default: UP Standby: 60 min, Circulation: 5)

- RO Standby Wash

Self-cleaning for 3 minutes is automatically performed every 120 minutes.

- RO Run Wash

RO Membrane Self-cleaning (for 3 minutes) is automatically performed every 60 minutes.

- Temperature

Evo-CB System stops operating if influx temperature exceeds a set level (default: 35°C).

- Level Sensor

The system is restarted when the water level of the tank reaches at about 80% under the system standby mode.

- Key tone

- Password

Initial password is 0001.

- Press Menu to save changes made and return to Menu.

4-5. Pure and Ultra pure water screen

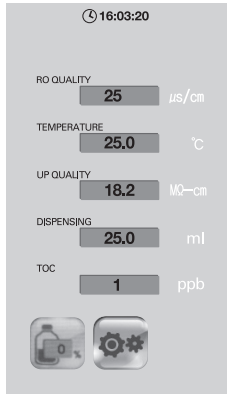

- RO Button activates pure water and UP button activates
- Quality and temperature are displayed.
- The normal range of pure water is 1~25 $\mu\text{s}/\text{cm}$ and that of ultra pure water is 18.2 $\text{M}\Omega\text{-cm}$.
- In the case of Dio VFT model, TOC level is indicated.

4-6. Quantity Control

- Ultrapure water can be collected in units of 100 mL.
- Press Run.
- Press Vol to open Dispenser Settings.
- Press ◀▶ to set the desired quantity.



Caution : Pump damage can occur if the maximum volume of a connected pure water tank is exceeded.

- Press Vol again to begin collecting ultrapure water.
- To stop, press Vol again.

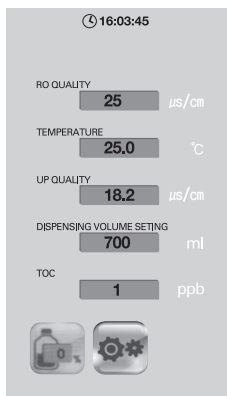

Quantity Control Setting
Screen

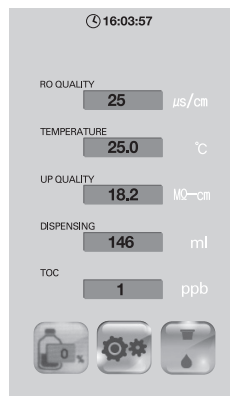

Collection-in-progress
Screen

4-7. Water Quality Printout

- Press the Print button is running to get a printout of water quality.

4-8. Filter Replace Alarm

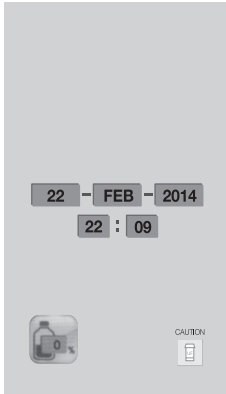

- A filter change icon is displayed seven days ahead of the required filter change. Press Quick to view the remaining life span of all filters.

4-9. USB Auto Save

- You can save water quality records automatically to a USB memory device.
 - Insert a USB memory device and press the Menu key in USB Print. Remove the USB memory device and insert it again at a desired time and press the Menu key in USB Print to save.
 - Water quality records are saved in Excel format on the hour from the start and the end of this function. Auto save does not take place if Evo-CB System is not working.

* Example : Auto save is not performed if USB Print starts at 17:03 and ends at 17:58. Two files are saved if USB Print starts at 16:57 and ends at 18:02 and it can be viewed on your PC.

Sample Screenshot

	A	B	C	D	E	F	G	H	I	J	K	L	M	N	O	P	Q
1	Time	Min.	Day	Month	Year	RO	Temp.	UP	Temp.	Inlet Temp.	PH	TOC					
2	16	0	7	NOV	2013	25	0	0.1	25	25	7	0					
3	17	0	7	NOV	2013	25	0	0.1	25	25	7	0					
4	18	0	7	NOV	2013	25	0	0.1	25	25	7	0					
5	19	0	7	NOV	2013	25	0	0.1	25	25	7	0					
6	20	0	7	NOV	2013	25	0	0.1	25	25	7	0					
7	21	0	7	NOV	2013	25	0	0.1	25	25	7	0					
8	22	0	7	NOV	2013	25	0	0.1	25	25	7	0					
9	23	0	7	NOV	2013	25	0	0.1	25	25	7	0					
10	24	0	7	NOV	2013	25	0	0.1	25	25	7	0					
11																	
12																	
13																	
14																	
15																	
16																	

Auto saved files do not have the item names shown in the sample screenshot. Refer to the sample screenshot and name the items yourself.

Section 5. System Maintenance

5-1. Replacing of the Dico-PC Pack, Dio Pack III

Open the front door and connect the Quick Connector. Before connecting the pack to the main unit, press down on the top part of the Quick Connector.



Caution : If left protruding, the top part of the Quick Connector can damage the O-ring in the main unit.

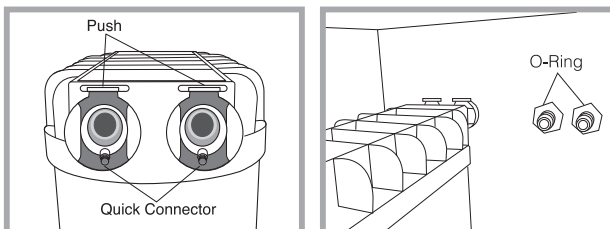

5-2. Replacing of the Dico-RO Membrane

- Remove the cover from the left side of the system with a screwdriver.
- Remove the tubing from the top and bottom.
- Pull out the RO Membrane Housing, turn its cover part counterclockwise, remove the RO Membrane that is installed inside, and push in a new RO Membrane.

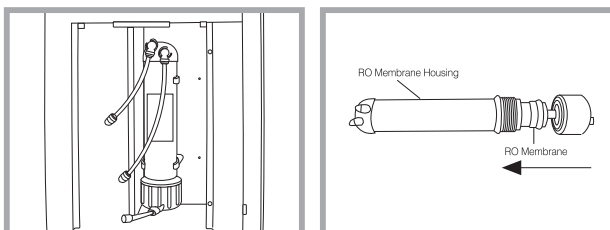

5-3. Replacing of the UV Lamp (For Dio UV, VF, VFT)

- Remove the cover from the left side of the system with a screwdriver.
- Remove the tubing from the top and bottom.
- Removed the clip-fixed UV lamp housing and turn its top counterclockwise to remove the lamp socket from the UV lamp.
- Replace the old UV lamp with a new one.
- Reassemble and install in the main unit.

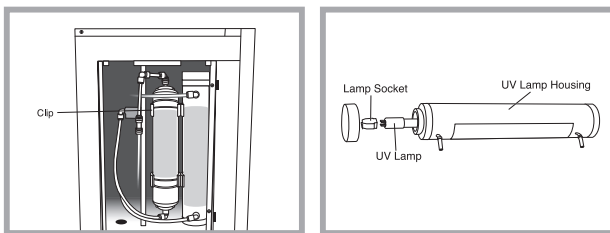

5-4. Replacing of the UF Filter, Final Filter

- Remove the Final Filter from the front of Evo-UP System by turning it clockwise.
 - Install a new Final Filter by turning it counterclockwise.
- In cases of Dio VF, VFT Model, UF Filter is installed instead of Final Filter.

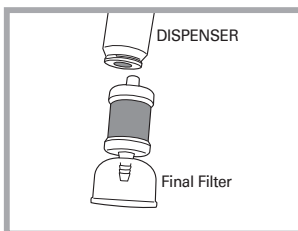

Caution : Do not turn the filter with excessive force to prevent damage.

5-5. System Resetting after filter replacing

- Select Filter on Menu.
- Press ◀▶ to select the replaced filter.
- Press △▽ to change USE Time to “1 day” and press Menu to return to Menu.

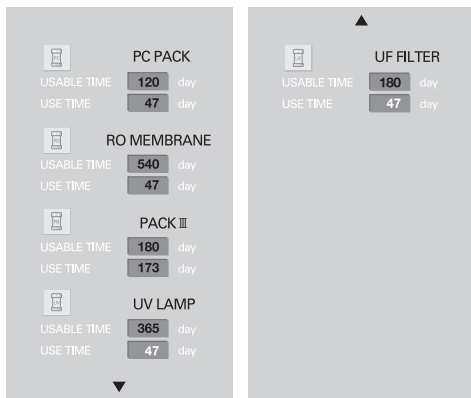

* Filter type can vary by model. Sample model in the photo : Evo-CB DioVFT



Caution : Changing USE TIME greatly affects water quality and optimum water quality guaranteed if extended excessively. Regular filter change is recommended.

5-6. Component Replacement Cycle

Consumable	P/N	Replacement cycle	Remark
Dico-PC Pack	ADPC28M	4 months	
Dico-RO Membrane	ADRM75M	18 months	
Dio Pack III	ADP III 28M	6 months	
UV Lamp (185/254nm)	ADVL85M	12 months	For Dio UV, VF, VFT
UF Filter	ADFF10M	6 months	For Dio VF, VFT
Final filter	ADFF02M	6 months	For Dio 10, 20

* Average life span of consumables can vary according to water quality and frequency of use.

* Always keep Dio Pack III and UF Filter refrigerated.

5-7. Maintenance

- Fuse replacing
 - Switch off the power and remove the power cord.
 - Assess the power cord unit at the side of the main unit.
 - Pull forward the part in the middle marked "Fuse" using a screwdriver.
 - Remove the fuse box with the hand. Two fuses, one being a spare, should be found.
 - 200–240 v or 110–120 v: T1.6A (T: Time lag fuse)

- Cleaning









Clean the exterior and interior (inside the door) of Evo-RO System as follows.

- Switch off the power and remove the power cord.
- Wet a clean soft cloth and wring it thoroughly. Wipe the surfaces clean.
Carefully wipe clean the microprocessor control panel (top panel of the main unit) with a dry soft cloth.
Never use cleaning liquids directly on any part of Evo-RO System.
Do not use alcohol, benzene, or thinner to clean as discoloration or disfiguration may occur.
- Remove any vapor formed on surfaces with a dry cloth.



Caution : Always remove the power cord before cleaning.

Section 6. System Alerts

Error	Solution
 REPLACE PACK I, II	Replace the PC Pack Refer to 5-1.
 REPLACE RO MEMBRANE	Replace the Dico-RO Membrane Refer to 5-2.
 REPLACE PACK III	Replace the Dio Pack III Refer to 5-1.
 REPLACE UV LAMP	Replace the UV Lamp Refer to 5-3.
 REPLACE UF LAMP	Replace the UF Filter Refer to 5-4.
 REPLACE FINAL FILTER	Replace the Final Filter Refer to 5-4.
 RO HIGH TEMPERATURE	Check the inflowing water temperature.
 UP HIGH TEMPERATURE	Check the inflowing water temperature.
 HIGH PRESSURE	Check the inflowing water pressure.

Contact the Mirae ST customer center if problems persist.



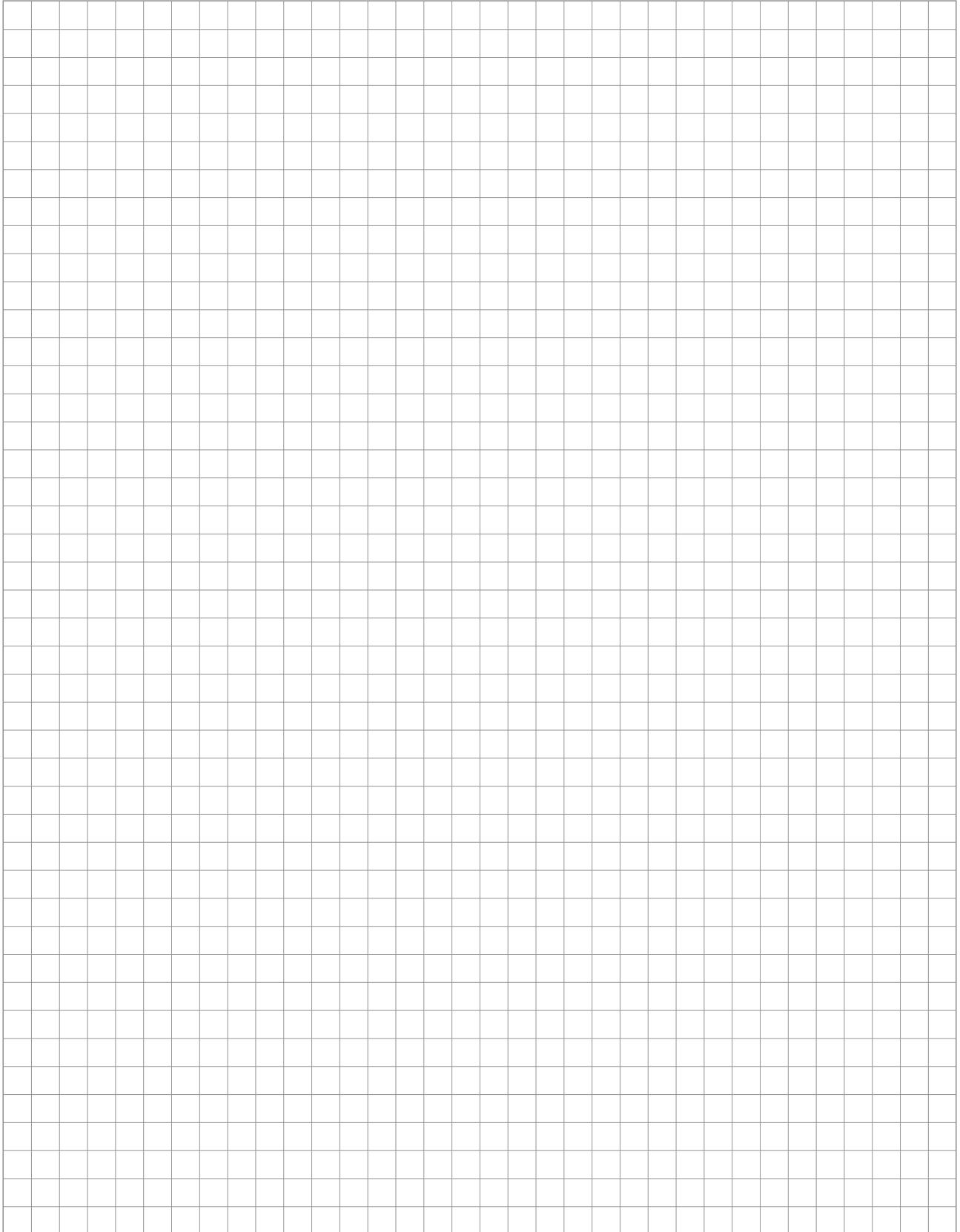

We strive to guarantee our customers the complete satisfaction.
MIRAE ST CO. LTD not only makes high quality products but we do our best
to provide the best after service to our customers.

We are always glad to receive feedbacks or any opinions from our
customers. If you have any inconvenience or something that we can be of
help, please don't hesitate to contact us.

Thank you!!



MIRAE ST Co., Ltd.

#717, Anyang-Megavalley, 268, Hagui-ro, Dongan-gu, Anyang-si,
Gyeonggi-do 431-767 S.Korea

Phone : 82-31-420-5753 **Fax** : 82-31-420-5978

Http : www.miraest.co.kr **E-Mail** : mrst@mrst.kr